

**Marine**

# BOS Power S2000 - IMO 3

MTU 12/16V 2000 M72 for fast vessels with high load factors (1B)

	ENGINE		SCR	
Engine with SCR	Dimensions (LxWxH) mm	Mass engine, dry [kg]	Dimensions (LxD) mm	Mass SCR system, dry [kg]
12V2000M72	1869 x 1293 x 1364	3680	2194 x 850	340 <sup>1)</sup>
16V2000M72	2287 x 1293 x 1404	4600	2247 x 950	385 <sup>1)</sup>

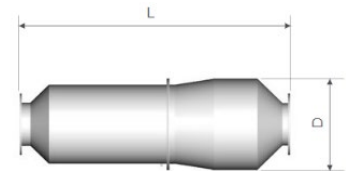
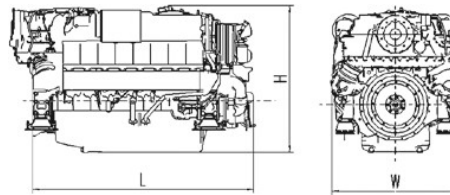
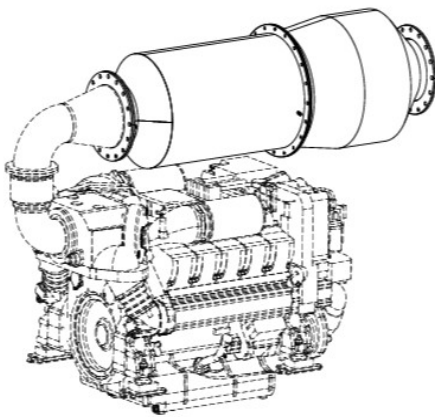

Typical applications: Fast ferries, wind mill service vessels, SAR, Patrol vessels (catamarans monohulls, surface effect ships) and displacement yachts

1) Weight of complete SCR system including catalyst, mixer, 100 l urea tank (dry), control cabinet, wiring and dosing unit

Engine type		12V 2000 M72	16V 2000 M72
Rated power ICFN	kW (bhp)	1080 (1450)	1440 (1930)
Speed	rpm	2250	2250
No. of cylinders		12	16
Bore stroke	mm	135/156	135/156
Displacement, total	l	26,8	35,7
Flywheel housing		SAE 0	SAE 0
Aftertreatment system		LF-type	LG-type
Max exhaust backpressure 2)	mbar	45	45
Exhaust emissions		IMO III	IMO III

1) IMO – International Maritime Organization

2) Including SCR system

Engine type		12V 2000 M72			16V 2000 M72		
Speed	rpm	2250	1950	1200	2250	1950	1200
Maximum power	kW	1080	1060	525	1440	1420	690
	bhp	1450	1420	705	1930	1905	925
Power on propeller curve (n 3)	kW	1080	720	170	1440	950	225
	bhp	965	635	155	1930	1275	300
Fuel consumption on propeller curve 1)	g/kWh	208	217	218	208	209	218
	l/hr	270.7	188.2	44.6	360.9	239.2	59.1
Urea consumption 2)	g/kWh	9.5	9.5	9.5	9.5	9.5	9.5

1) Tolerance +5% per ISO 3046, Diesel fuel to DIN 590 (low sulphur fuel) with a min L.H.V. of 42800 kJ/kg (18390 BTU/ib)

2) AdBlue 32,5% Urea, tolerance 5%

Engine system	Standard equipment
Exhaust after treatment system	SCR-system with integrated mixer and catalyst. Air assisted Urea injection.
Engine starting system	Electric starter 24V
Auxiliary PTO	Alternator, 80A, 28V, 2 pole
Engine oil system	Gear driven lube oil pump, lube-oil duplex filter with diverter valve, lube-oil heat exchanger, handpump for oil extraction
Engine fuel system	Fuel feed pump, fuel hand pump, fuel pre-filter, fuel main filter with diverter valve, on-engine fuel oil cooler, HP fuel pump, jacketed HP fuel lines, injection nozzles (CR system), flame proof hose lines, leak-off fuel tank level monitored
Engine cooling system	Coolant-to-raw water plate core heat exchanger, self-priming centrifugal raw water pump, gear driven coolant circulation pump
Engine combustion air system	Sequential turbocharging with 2 water-cooled exhaust-gas turbochargers, on-engine set of combustion-air filters
Engine exhaust system	Triple-walled, liquid-cooled, on-engine exhaust manifolds, single centrally located exhaust outlet, 1 exhaust bellow horizontal discharge
Engine mounting system	Resilient mounts at free end
Engine management system	Engine control and monitoring system (ADEC)

Engine system	Optional equipment
Auxiliary PTO	Alternator, 140A, 28V, 2 pole, bilge pump, on-engine PTOs
Oil system	Centrifugal oil filter, oil replenishment system
Fuel system	Duplex fuel pre - filter
Cooling system	Coolant preheating system
Exhaust system	1 exhaust bellow vertical discharge
Mounting system	Resilient mounts at driving end
Engine Management system	In compliance with Classification Society Regulations
Monitoring / Control system	BlueVision New Generation MCS, RCS
Power Transmission	Torsional resilient coupling
Classification	ABS, BV, CCS, DNV-GL, KR, JG, LR, NK, RINA

> Power definition according ISO 3046

> Intake air temperature 25°C/Sea water temperature 25°C

> Intake air depression 15 mbar / Exhaust back pressure 30 mbar

> Barometric pressure 1000 mbar

> Power reduction at 45°C/32°C: none

Specifications are subject to change without notice. All dimensions are approximate.

For complete information refer to installations drawing. For further information consult your MTU distributor/dealer. May have options that are not fitted as standard to the standard engine.

